

# **p70 / p70r**

## **Pilot controller**

### Quick reference

**ENGLISH**

Document number: 86142-1

Date: 02-2011

The Raymarine logo is positioned in the bottom left corner of the page. It features the brand name "Raymarine" in a bold, black, sans-serif font, followed by a registered trademark symbol (®). The logo is set against a light gray background that is part of a larger graphic design consisting of several overlapping, curved bands in shades of gray and black that sweep across the bottom of the page.

**Raymarine®**

**ENGLISH**

Document number: 86142-1

Date: 02-2011



## Warning: Maintain a permanent watch

Always maintain a permanent watch, this will allow you to respond to situations as they develop. Failure to maintain a permanent watch puts yourself, your vessel and others at serious risk of harm.

## Pilot controls

Control layout and functions.

### p70 8-button pilot controller

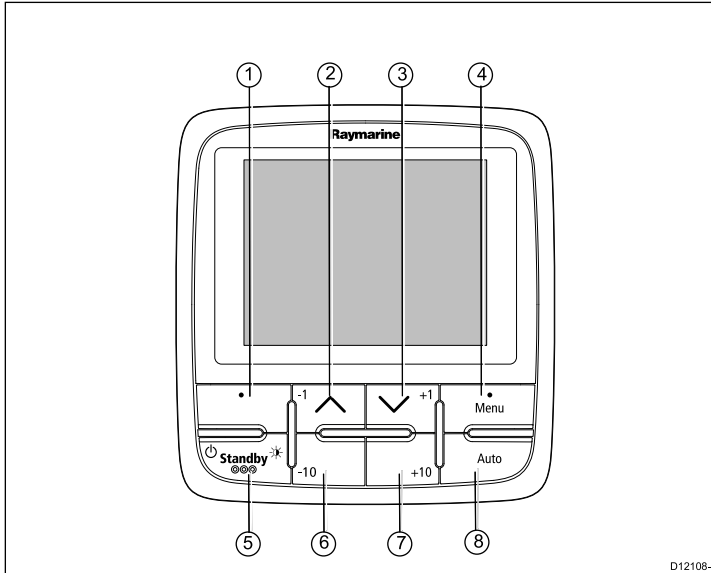

D12108-1

Item	Description
1.	<b>LEFT SOFT BUTTON</b> Cancel, Back, mode selection.
2.	<b>UP BUTTON / -1</b> Up navigation, Adjust Up, Decrease angle.
3.	<b>DOWN BUTTON / +1</b> Down navigation, Adjust Down, Increase angle.
4.	<b>RIGHT SOFT BUTTON</b> Menu, Select, OK, Save.
5.	<b>STANDBY BUTTON</b> Disengage pilot, Manual control, Power, Brightness.
6.	<b>-10 BUTTON</b> Decrease angle.
7.	<b>+10 BUTTON</b> Increase angle.
8.	<b>AUTO BUTTON</b> Engage Auto pilot.

## p70r rotary pilot controller

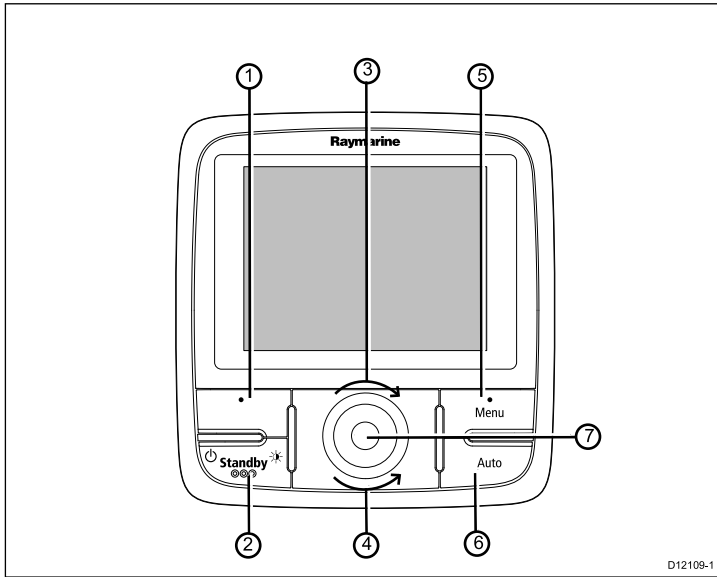

D12109-1

Item	Description
1.	<b>LEFT SOFT BUTTON</b> Cancel, Back, mode selection.
2.	<b>STANDBY BUTTON</b> Disengage pilot, Manual control, Power, Brightness.
3.	<b>ROTARY CLOCKWISE</b> Down navigation in list, Adjust Up, Increase angle (locked heading), adjust numerical values, power steer.

Item	Description
4.	<b>ROTARY ANTI-CLOCKWISE</b> Up navigation in list, Adjust Down, Decrease angle (locked heading), adjust numerical values, power steer.
5.	<b>RIGHT SOFT BUTTON</b> Menu, Select, OK, Save.
6.	<b>AUTO BUTTON</b> Engage Auto pilot.
7.	<b>ROTARY END PUSH BUTTON</b> Menu, Select, OK, Save.

The pilot controller supports the following combination button presses:

### Combination button press

Buttons	Action
<b>STANDBY and AUTO.</b>	Puts pilot in to Wind Vane mode.
<b>-1 and -10</b> or <b>+1 and +10.</b>	AutoTack (in wind vane mode), AutoTurn

## Powering the pilot controller on

- Press and hold the **STANDBY** button for 1 second, until the Raymarine logo appears.  
The pilot controller will load to the mode page.

## Powering the pilot controller off

1. From any data page press and hold the **STANDBY** button.  
After 1 second a power down pop up will appear.
2. Continue to hold the **STANDBY** button for a further 3 seconds to complete the power off.

**Note:** The pilot controller cannot be turned off whilst in **AUTO** mode.

## Adjusting the displays brightness

To adjust the brightness of the individual display:

1. Whilst in a favorite page momentarily press the **LEFT SOFT** button.  
This will open the brightness setting screen.
2. Use the **UP** and **DOWN** buttons to change the brightness percentage to the required level.
3. Press the **RIGHT SOFT** button to confirm new brightness and go back to the favorites page you were on.

## Simulator

The Simulator mode enables you to practice operating your display without live data from a transducer or other connected peripherals.

The simulator mode is switched on/off in the **Simulator** option from the **Setup Menu**.

**Note:** Raymarine recommends that you do NOT use the simulator mode whilst navigating.

**Note:** The simulator will NOT display any real data, including any safety messages (such as those received from AIS units).

**Note:** Any system settings made whilst in Simulator mode are not transmitted via SeaTalk to other equipment.

## Mode page

The mode page is the initial screen displayed after set up of the device. If the device is being switched on for the first time, the user is taken to the initial Set up wizard. Once the device has been set up they will then proceed to the Mode page. The mode page is used to show what mode you are in and also relevant pilot information for that mode.

The selection of vessel type during the initial set up determines which profile and menu structure the pilot will be set to (e.g. Power, fishing or sailing boat):

The modes available will depend on the vessel type chosen during initial set up.

- Pattern 1 — Fishing boat only (this will take you to the most common pattern for the last 10 selections).
- Pattern 2 — Fishing boat only (this will take you to the second most common pattern for the last 10 selections).
- Pattern — Power and fishing boats only.
- Track — all profiles.
- Wind vane — sailing boat only.
- Power steer — all profiles (p70r rotary controller and joystick only).
- Shortcut key- allows you to set which pilot mode is mapped to the **left soft** button when in pilot view.

# Available pilot views

Pilot views are used whilst in pilot modes to present course and system data on the pilot controller display.

There are 5 pilot views to choose from:

Description	Example
Graphical (default)	
Large	

Description	Example
Standard	
Multiple	
2D	

## Setting the pilot view

To set the pilot view to your desired layout:

1. Go to the **Pilot view** menu: **Main menu > Pilot view**.
2. Highlight and select **View type**.
3. Highlight the required view:
  - Graphical
  - Large
  - Standard
  - Multiple
  - 2D
4. Press **SELECT** to save the view as default.

## Standby mode

In Standby mode you have manual control of the helm and the display shows the vessel's current compass heading.

You can disengage any autopilot mode and return to manually steering at any time by pressing **STANDBY**.

## Auto mode

### Steering automatically to a heading

You can use your autopilot system to steer automatically towards a heading.

1. Steady the vessel on the required heading.
2. Press **AUTO**.  
The autopilot is now in AUTO mode and will steer to the chosen heading, shown on the display.

3. You can return to manual steering at any time by pressing **STANDBY**.

## Changing course in auto mode

To change course whilst in AUTO mode:

1. Use the **-1** and **-10** button, or turn the rotary controller anticlockwise to change the vessel's course to port.  
Pressing **-1** button will increment the course to port by 1° and **-10** will increment by 10°.   
Turning the rotary controller 1 click anticlockwise will increment the course to port by 1° .
2. Use the **+1** and **+10** buttons, or turn the rotary controller clockwise to change the vessel's course to starboard.  
Pressing **+1** button will increment the course to starboard by 1° and **+10** will increment by 10°.   
Turning the rotary controller 1 click clockwise will increment the course to Starboard by 1° .

e.g. pressing the **-1** button four times, or turning the rotary 4 clicks anticlockwise will result in a 4° course change to port.

## Alarms

Alarms are used to alert you to a situation or hazard requiring your attention.

Some examples of alarms are:

- Anchor alarm — Used when anchored, this alerts you to a change in depth which could mean that the chain length requires adjusting.
- Depth and speed alarms — These alarms alert you when your depth or speed moves outside of specified limits, for example a minimum depth.

- MOB (Man Overboard) alarm — Received from an MOB system.

When an alarm occurs, a message is displayed and an audible alarm may sound.



You can either:

- Silence the alarm, or
- Silence the alarm and edit the alarm settings.

**Note:** With the exception of alarm clock, speed and sea temp SeaTalk systems will only be able to switch alarms on/off, SeaTalk<sup>ng</sup> systems will be able to adjust settings.



**Owner notes:**

**Owner notes:**



**Raymarine®**  
A FLIR COMPANY

[www.raymarine.com](http://www.raymarine.com)

