



**VOLVO PENTA DIESEL
AND GASOLINE ENGINES**

**LAYING-UP AND
LAUNCHING GUIDE**

TIME WELL INVESTED

This guide covers most of the items to be checked and seen to on your engine and drive when laying up and launching. Although it won't take more than a couple of hours of your time each year, your engine will run more reliably and economically and use less fuel, with less chance of unnecessary breakdowns. Life at sea will be safer.

You will find more detailed information in your engine instruction book and our do-it-yourself manuals. Or consult your authorized Volvo Penta dealer, he will be pleased to carry out your servicing and maintenance, if you do not wish to do it yourself. Certain complicated jobs are, of course, best left to an authorized dealer since they call for both specialized knowledge and special tools.

Always use Genuine Volvo Penta Parts. That way you can be confident that the parts you use will be of the right quality and fit perfectly. And make sure you have tools on board and that your on board repair kit is complete.

Remember the environment – collect any oil, coolant, degreaser, paint, etc., and dispose of them in the proper containers.



The time intervals mentioned by us are only general and can vary between different engine types. The operator's manual will give you the proper intervals for your particular engine. However, entirely different intervals apply, if you use the engine for commercial purposes or in very polluted waters.

Oil and oil filter changes	4
Cooling system	8
Thermostat	10
Impeller	11
Cooling water hoses/Exhaust hoses	12
Drive belts	13
Fuel system	14
Air filter/Air intake silencer	15
Electrical system	16
Oil changes - drive/reverse gear	18
Drive	20
Propeller	22
Cleaning and painting	23
Ventilation	24
Corrosion protection - inside the engine	25
Ignition system	26



This symbol represents work in connection with the laying-up season

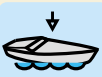

This symbol represents work in connection with the launching season

⚠ A yellow box represents warning text

OIL AND OIL FILTER CHANGES

You should change the engine oil and oil filter after approx. 100 hours of operation, or at least once per season.

Choose Volvo Penta engine oil which has good inhibiting qualities and you will not need to add any special inhibiting oil for a normal winter lay-up.

A new oil filter will remove soot and metal particles from the oil and prevent unnecessary engine wear. Genuine Volvo Penta filters are tested and specially designed to suit each particular engine type.

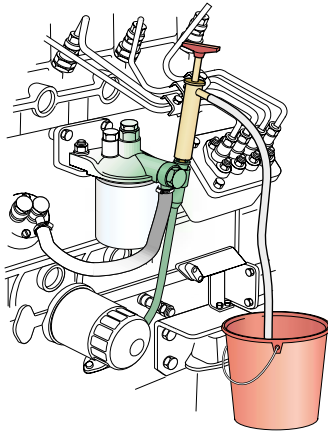

Run the engine warm before changing the oil. It is easier to do this when the boat is still in the water (it can also be done in connection with engine inhibiting).

Switch off the engine and use an oil bilge pump to pump out all the engine oil through the dipstick hole. Change the oil filter and fill up with the right amount of Volvo Penta engine oil. Also change transmission oil, please refer to the "Oil changes – drive/reverse gear" chapter. Run the engine for a while. Check for oil leaks.

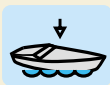
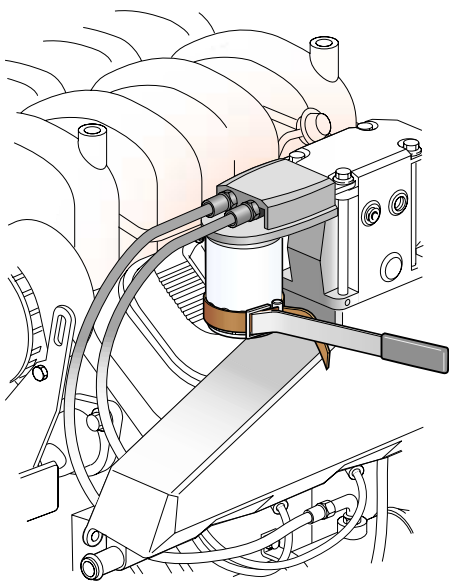

Check the oil level before starting the engine.

COOLING SYSTEM

INHIBITING SEA WATER COOLED ENGINES

Regular maintenance and servicing of the cooling system is an effective way of preventing damage from overheating. It is also important to inhibit the cooling system for the lay-up season in order to avoid frost damage and corrosion.

⚠ Work on the cooling system is best carried out on land. Otherwise there is a risk of water getting into the boat.

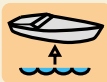
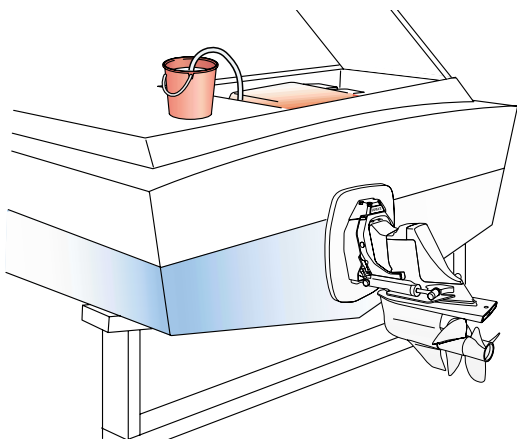

The engine and reverse gear cooling water ducts must be flushed and drained off. Detach the suction pipe from the inside of the shield on the Aquamatic drive or from the reverse gear. Connect a hose to the suction pipe and insert it in a bucket of fresh water. Make sure that the bucket is continually replenished with fresh water. Let the engine idle until it warms up enough to open the thermostat.

⚠ Never let the water pump run dry.



It is important to let the engine run for a while, in order to flush away any sludge and salt that could otherwise cause rusting. Then switch off the engine. Insert the free end of the hose into a solution of water and Volvo Penta coolant. Allow the liquid to circulate for a while, without the bucket becoming empty. Switch off the engine and replace the suction pipe.

N.B. Leave the liquid in the system, as it provides good protection against freezing and corrosion.

Check and clean sea water filter, if fitted.

If you wish to protect the engine over a longer period than the normal lay-up time, use Volvo Penta emulsifying inhibiting oil, as it is specially designed for the cooling water ducts. Follow the same procedure as above, but empty the system completely, as the liquid does not offer any protection against frost.



Check that all plugs and drain cocks are fully closed.

N.B. Some engines have zinc anodes on the plugs and these act as sacrificial anodes in the cooling system. An anode must be replaced when about 50% of its volume has been used up.

COOLING SYSTEM

INHIBITING FRESH WATER COOLED ENGINES

Regular maintenance and servicing of the cooling system is an effective way of preventing damage from overheating. It is also important to inhibit the cooling system for the lay-up season in order to avoid frost damage and corrosion.

⚠ Work on the cooling system is best carried out on land. Otherwise there is a risk of water getting into the boat.

The fresh water cooled engine has two cooling systems. The engine block and cylinder head are fresh water cooled. But the oil cooler, heat exchanger and, on some engines, exhaust pipes, are sea water cooled and should be inhibited in accordance with the section on sea water cooled engines.

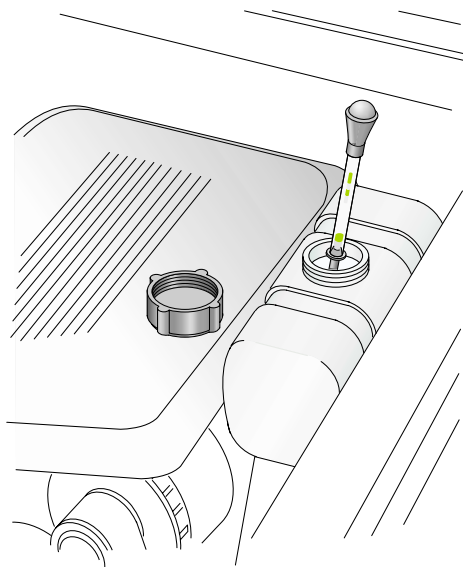



Check the freezing point of the coolant with a hydrometer and top up the cooling system if necessary. The coolant mixture loses its corrosion protective qualities with time and should therefore be changed every other year.

N.B. Avoid mixing different types of coolants since it drastically diminishes the corrosion protective qualities.

Do not mix coolant with other additives.

Check and clean sea water filter, if fitted. Inhibit the sea water cooled part of the engine in accordance with the section on sea water cooled engines (see page 7).



Check the level of the fresh water system and make sure that all plugs and draining cocks are fully closed.

N.B. Some engines have zinc anodes on the plugs and these act as sacrificial anodes in the cooling system. An anode must be replaced when about 50% of its volume has been used up.

THERMOSTAT

If your instrument panel has a temperature gauge you will be able to see whether the engine stays at the right working temperature or not. Excessive temperatures are often caused by blockage in the coolant intake, cooling ducts or heat exchanger, or by a defective impeller. Too low a temperature is usually caused by a faulty thermostat.

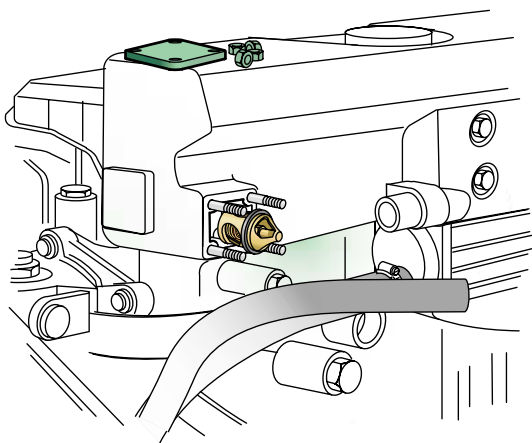

Check the function of the thermostat by removing it and placing it with a thermometer in a pan of water. Heat the water and see if the thermostat opens at the temperature indicated in the operator's manual. If not, replace the thermostat.

IMPELLER

The impeller pumps cooling water through the engine cooling system. It is, therefore, an extremely vital safety feature. Replace the impeller at least every two years. However, a worn or damaged impeller must be replaced immediately. Make a habit of keeping a spare impeller, and seal for the impeller pump cover, on board.

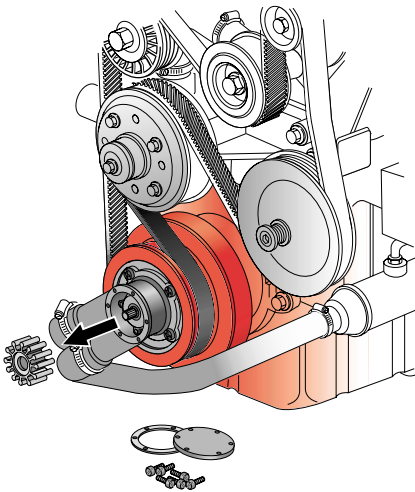

After inhibiting, unfasten the sea water pump cover and remove the impeller. Rinse it well and keep it in a tightly sealed plastic bag in a cool place during the lay-up period.



Install a perfect impeller and impeller cover together with a new seal.

COOLING WATER HOSES / EXHAUST HOSES

As rubber becomes brittle with time, you should occasionally check the hoses for any signs of cracks or damage

⚠ Leaking cooling water hoses are a safety hazard and can cause the engine to overheat or the boat to become filled with water.

⚠ Leaking exhaust hoses can cause dangerous exhaust fumes on board and allow water to get into the boat.

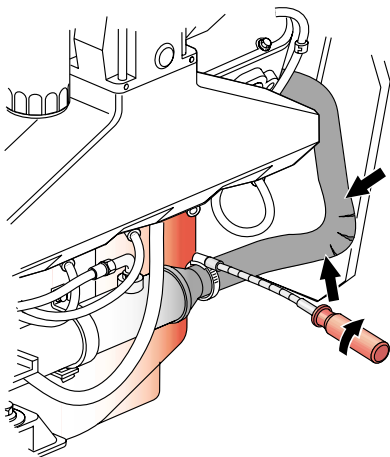

Carefully inspect the hoses and clamps of the cooling system and exhaust system. Replace those hoses which do not feel soft and pliable. Tighten all hose clamps.



Check the condition of the hoses and that all hose clamps are securely fastened.

DRIVE BELTS

Check on the generator belt and the fresh water pump drive belt a few times a year to make sure that they are properly tensioned. Make sure that they are not cracked or frayed. A perfect drive belt gives a better generator charging effect while, at the same time, reducing the risk of overheating. Always keep spare belts on board. Genuine Volvo Penta drive belts last much longer.

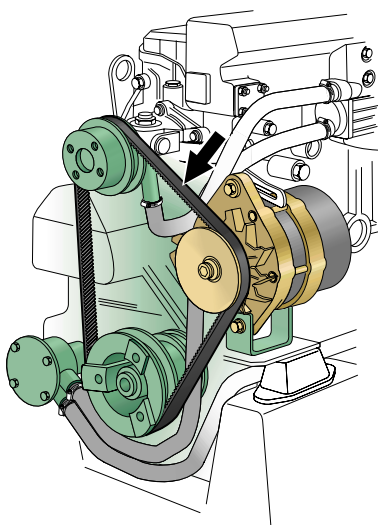

Check the condition of the belts.
Replace them if necessary.



After replacement – tighten the belts
and adjust the tension.

N.B. Check the belt tension once more
after a few hours running. Readjust, if necessary,
according to the Operator's Manual.

FUEL SYSTEM

It is important, when overhauling and servicing the fuel system, to consider the safety aspects and always use Genuine Volvo Penta Parts. It is particularly important to avoid getting any dirt into the system.

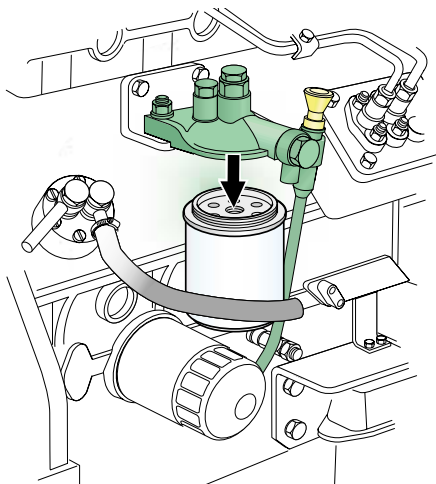

Fill the fuel tank for the lay-up period and you won't have to worry about condensation in the tank.

Check before you fill up that there are no special rules applicable to the site where the boat is laid up, about the quantity of fuel aboard.



Venting the fuel system (see operator's manual) and run the engine warm, while checking for leaks.

⚠ Switch off the engine immediately if you discover any leaks.

AIR FILTER / AIR INTAKE SILENCER

If your engine has an exchangeable filter element, it should be changed at least once per season.

An engine with a clean air filter can work more efficiently and uses up less fuel.

Use Genuine Volvo Penta filters, they are specially designed and tested for each particular engine type.

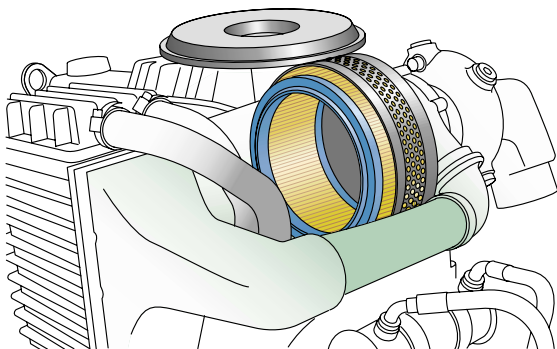

Change the filter element or clean the air intake silencer. Also replace the crankcase ventilation filter (if any).

ELECTRICAL SYSTEM

Sea air, which can be very humid and salty, presents a tough environment for the electrical system to operate in. The electrical system of the engine can be affected by creeping current, oxidation and voltage drop if you do not overhaul it regularly.

Make sure that the wires are undamaged and have not been subjected to bilge water. Otherwise there is a risk that leakage currents can get to the engine/drive or to the bilge water in the bilge. Serious corrosion damage can occur within a short time if leakage currents knock out the galvanic corrosion protection.

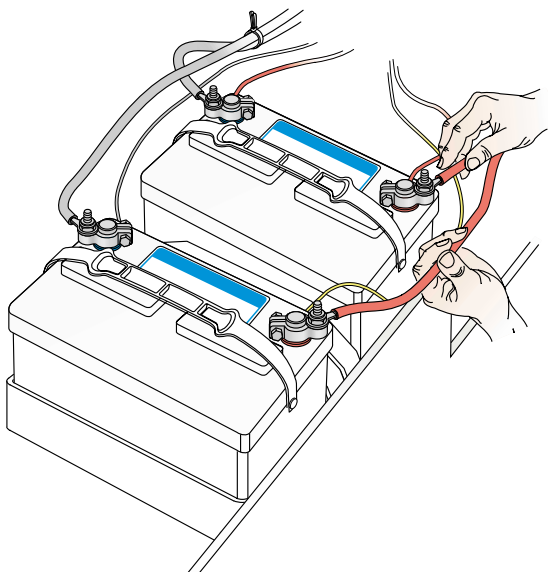

⚠ Important! A battery will be seriously damaged if discharged for longer periods. A discharged or badly charged battery can be ruined by freezing.



Remove the battery cables, clean the cable clamps and apply the appropriate type of grease to the battery poles.

Check the electrolyte level and charge the batteries. Batteries discharge when not in use, so you should recharge the batteries once a month, or once every two months, depending on storage temperature. The warmer the storage conditions, the faster the discharging process. The battery can be left on board if it is fully charged.

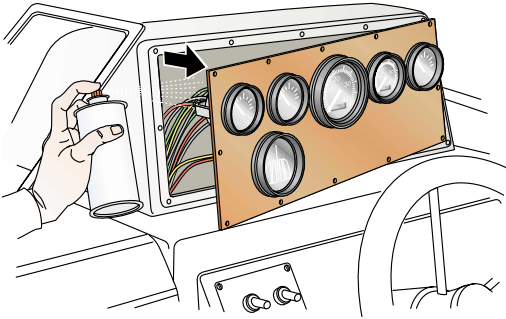

Clean and dry dirty and damp cables. Spray the connection points, contacts and fuse holders on the engine and under the instrument panel with Volvo Penta Universal Oil. Also loosen and clean any oxidized connection points.

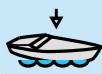

Check all fuses and make sure that there are spare fuses on board. Connect the fully charged battery and grease the poles with pole grease.

OIL CHANGES DRIVE/REVERSE GEAR

⚠ It is absolutely vital that you follow the safety recommendations in the operator's manual very carefully when you work with the drive and shield. Otherwise, you run the risk of seriously hurting yourself.

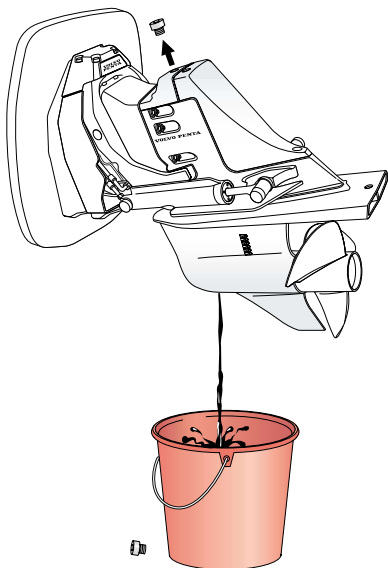

Change the oil in the drive/reverse gear. Be careful to use the right oil quality. Fill up to the right level and run the engine for a moment to make the oil circulate. If the old oil looks grey, it could be the result of water leaking into the drive. Contact your authorized Volvo Penta workshop if your oil looks grey.



Check the oil level.

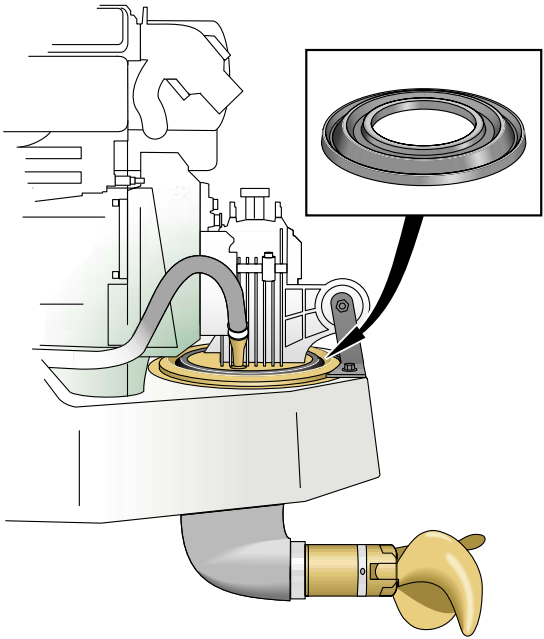

If you have an S-drive, the rubber seal between drive and engine bed has to be checked every year. If damaged, it must be replaced with a new seal immediately. Otherwise it should be changed every seventh year.

DRIVE

When replacing the rubber bellows the drive must be dismantled first. Let your workshop deal with this. However, if you feel that you can manage the job yourself, be sure to follow the directions in the do-it-yourself manual very carefully.

The bellows are subjected to tremendous wear from movement and from salt and impurities of the air and water. If water gets in via the drive joint bellows it can cause extensive direct damage and, in many cases, also costly subsequent damage. So replace the bellows regularly (at least every other year).

N.B. If the boat is used in fresh water (or brackish water containing little salt) the drive anode should be replaced with a magnesium anode.

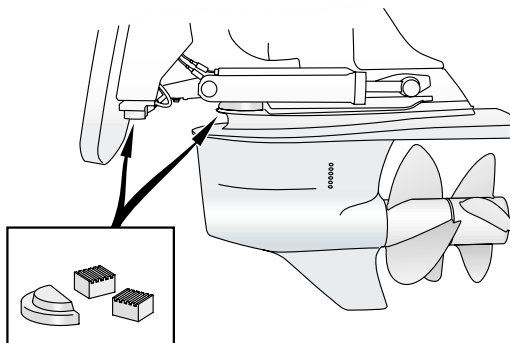

Carefully check the exhaust bellow and drive joint bellow, if you have not already done so when laying up. Check that the hose clamps on the bellows are firmly tightened and lubricate the grease nipples on the drive and steering fork (use a grease gun).

Reverse gear engines: Check the propeller shaft seal. Vent the bushing and apply water repellent grease into the seal.

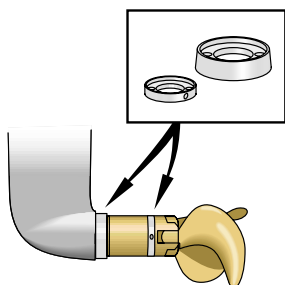

Check the zinc or magnesium anodes on the drive and shield. The anodes must be replaced if they are more than half used up. Use Genuine Volvo Penta anodes, since the wrong mix of material in the anode can lead to serious corrosion damage to the drive and propeller.

⚠ Remember that you must never paint over the anodes! The mounting surface must also be scraped clean, down to the bare metal, before installing any new anodes.

⚠ Warning!
You must make absolutely sure to lock/secure the drive in the folded-up position when working with the drive or shield. See operator's manual.

PROPELLER

A propeller must be in good condition to give you maximum output from your engine. A damaged propeller causes vibrations and reduced speed. In bad cases it can even cause bearing damage. Even minor damage to the propeller can easily lead to cavitation (looks like corrosion damage). Repair such damage and paint where necessary. And always keep a spare propeller on board.

The mechanism of the folding propeller must be greased with Volvo Penta water resistant grease. Please see the detailed instructions in the manual when removing and refitting propeller/s.

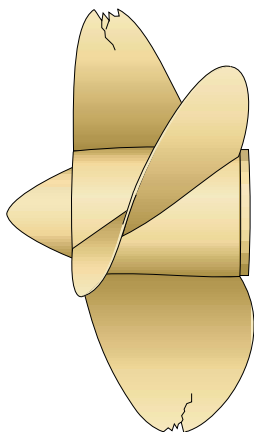

Remove the propeller/s and grease the propeller shaft/s with Volvo Penta water resistant grease.



Refit the propeller/s. Remember to grease the shaft/s first.

CLEANING AND PAINTING



Clean the engine, reverse gear and drive with a degreasing agent. If the paintwork has been damaged, it should be repaired as soon as possible in order to avoid corrosion. A clean engine is easy to work with and any damage or leakage can be discovered quickly.

Flush the drive with fresh water and remove algae and shells. Pay particular attention to the areas around the bellows and trim cylinders. Check the whole drive for damaged paintwork. Remove damaged paint and clean down to the bare metal with wet sandpaper. Then paint with Volvo Penta primer and top coat.

N.B. It is important to use Genuine Volvo Penta paint, since other paints can contain metals or metal oxides, causing galvanic currents. The sacrificial anodes must not be painted.



Paint the drive with Volvo Penta anti-fouling paint that is approved for use on aluminium drives.

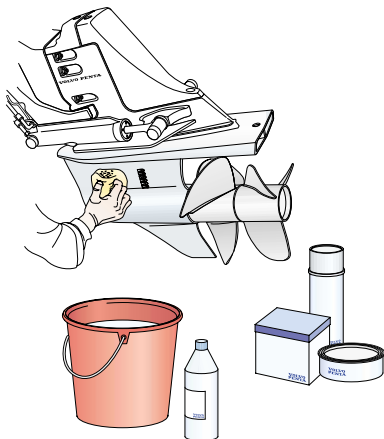

VENTILATION

Be careful to ensure good ventilation during the lay-up period. The air must be allowed to circulate throughout the boat. Keep the doors and hatches, including the engine compartment door, open in order to avoid condensation and mould.

Clean the engine compartment. A clean engine compartment is a prerequisite for maximum safety on board, and makes servicing work that much more agreeable.

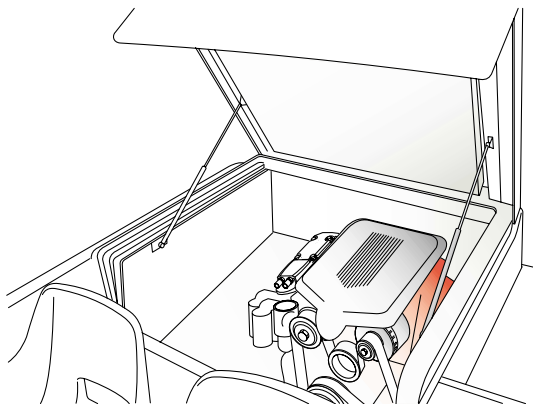

⚠ Important!

There is an operator's manual, providing you with more detailed information, on each particular engine.

IGNITION SYSTEM

Maintaining the ignition system is important in order for the engine to run well and consume less fuel. If you do not have the right equipment and knowledge for the job, then all adjustments to the engine ignition system should be carried out by an authorized workshop. Faulty adjustment of the ignition can result in engine damage and reduced fuel economy.

Use Genuine Volvo Penta components for the ignition system; they meet all marine safety requirements.

Make it a rule to change spark plugs at least once every year. This way you will prevent any starting problems, back-firing, etc. The operator's manual shows you what type of spark plug to use.

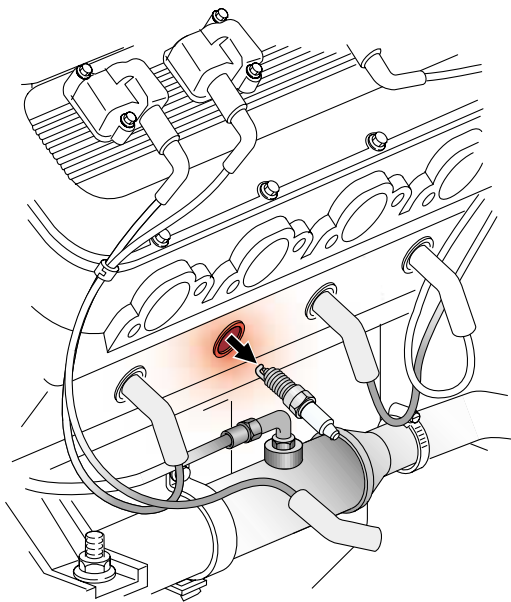



It is important, from a safety point of view, that all parts are clean and dry.

Clean and dry the ignition cables and distributor cover, loosen the distributor cover and clean and dry inside. Spray inside and outside, using a moisture-repellant spray. Replace any damaged or worn parts.



Install new spark plugs. If the engine is equipped with breaker points, these should be replaced, if necessary. Also

replace the condenser. Clean and dry the ignition cables and distributor cover. Let an authorized Volvo Penta workshop overhaul the ignition point setting, if you do not have access to special tools.

THE EASY WAY TO DEPENDABLE ENGINES

If you pay attention to simple maintenance jobs on your engine and drive you will reduce your running costs and increase your safety afloat. But it is just as important to ensure that the parts are Genuine Volvo Penta Parts. To locate your nearest Volvo Penta dealer, please go to www.volvopenta.com



**VOLVO
PENTA**

www.volvopenta.com